

INSTALLATION INSTRUCTION REAR STABILIZER BAR

Thank you for purchasing a quality Hellwig Pro

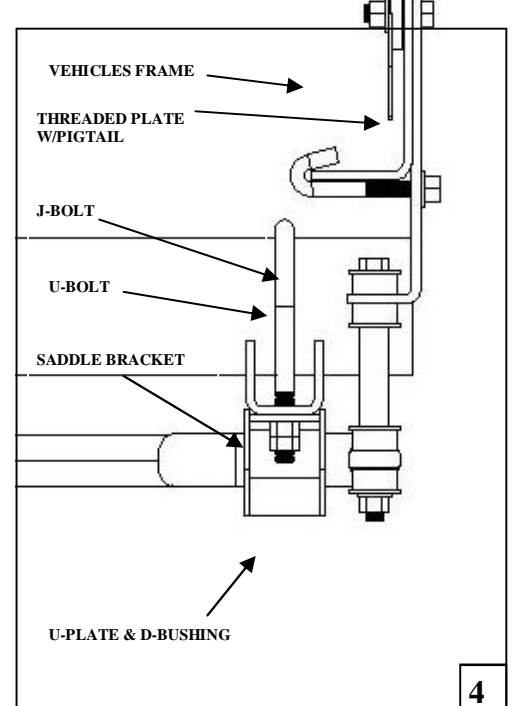

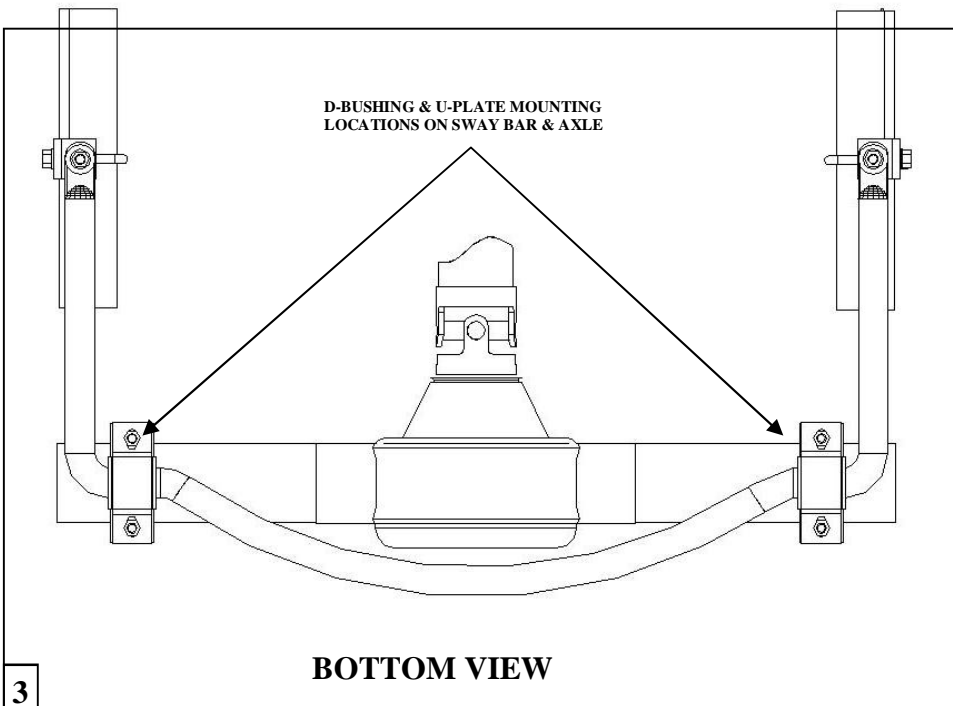
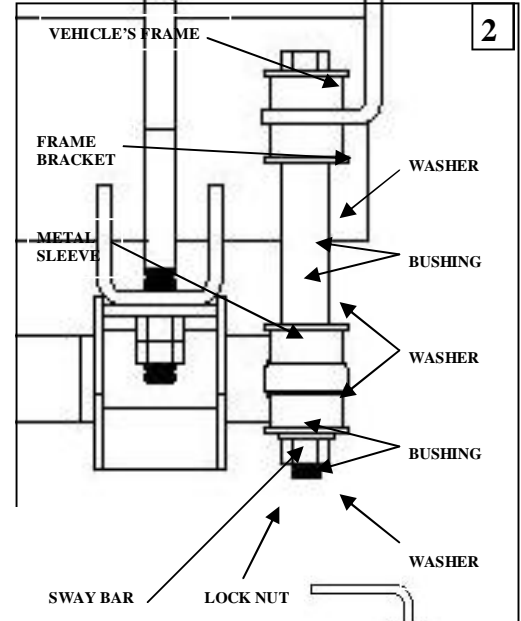
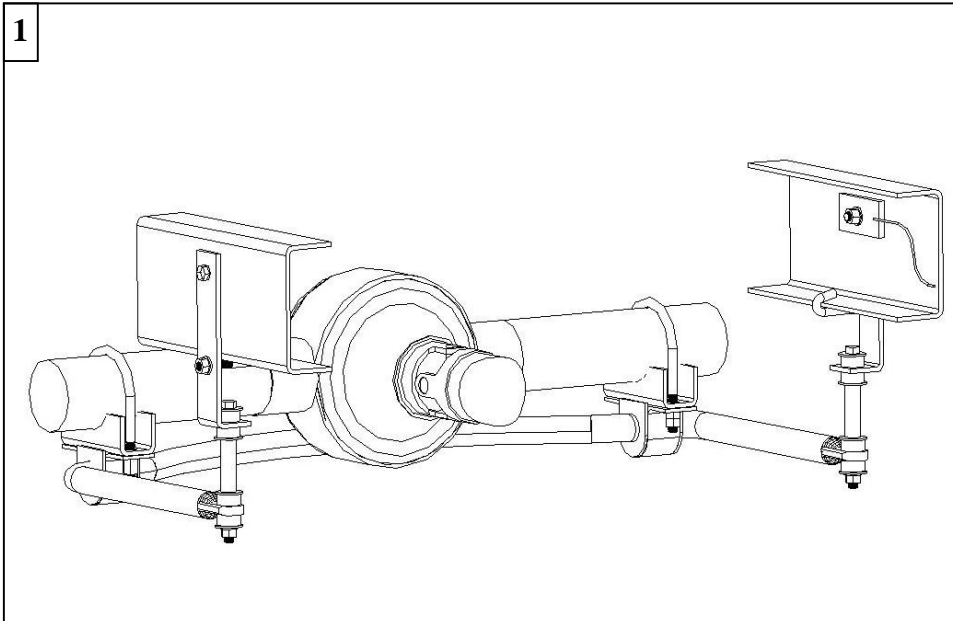

559-734-7451 800-367-5480 FAX 559-734-7460

TORQUE TABLE

BOLT SIZE: 3/8" = 20-30 ft. lbs. – 7/16" = 35-45 ft. lbs. – 1/2" = 50-70 ft. lbs. – 9/16" = 70-90 ft. lbs.

SAFETY: BEFORE STARTING YOUR INSTALLATION, BE SURE TO SET PARKING BRAKE AND CHOCK TIRES.

NOTE: TO EASE INSTALLATION AND TO PROPERLY ADJUST BAR, THE WEIGHT OF THE VEHICLE MUST BE ON THE SUSPENSION, AS IF DRIVING DOWN THE ROAD. DO NOT RAISE VEHICLE BY FRAME.

NOTE: THIS SWAY BAR IS DESIGNED TO MOUNT BELOW THE REAR AXLE WITH THE ARMS TOWARDS THE FRONT OF THE VEHICLE.

1. Place the U-bolts over the axle tubes just to the inside of the lower shock mount brackets. Position the U-bolts under the brake lines at the axle so no damage can occur when the U-bolts are tightened.
2. Place the sway bar under the axle tubes so that the flat areas of the bar are slightly rearward of the axle. **SEE PHOTO (3).**
3. Position the D-bushings on the flat areas of the sway bar to line up with the U-bolts on the axle. Place the U-plates over the bushings. Install the saddle brackets on axle U-bolts. Raise the sway bar and attach the U-plates onto the U-bolts with mounting hardware provided. **Leave loose at this time to allow for adjustment later.**
4. Locate the frame brackets. Install the end links on the short leg of the frame brackets as in photo (2) end link , flat washer , end link bushing. Insert thru hole at the frame bracket , install bushing , flat washer and steel; sleeve. Locate the pre-drilled holes on the vehicles frame in front of the rear axle assy. Using the threaded plate w/pigtail attach the frame bracket from the outside with the short leg pointing towards the drive line assy. Do the same to opposite side. Leave loose at this time to allow adjustment later. **SEE PHOTO (4).**
5. Raise the sway bar arms up to the mounted frame brackets. Complete the end links assy, washer , bushing , sway bar, bushing, flat washer and lock nut. **SEE PHOTO (2).** Tighten just slightly that the bushings start to bulge or damage can occur to the poly-bushings.
6. With the sway bar properly aligned, sway bar center at the axle and the end link assemblies straight up and down as possible. Torque mounting hardware at the axle and vehicle's frame to specified rates. Check for clearance on all under carriage components, electrical wires, exhaust, shocks, brake and fuel lines.
7. Test drive your vehicle re-check your installation re-adjust and tighten as needed. After one week of driving re-check your installation. Re-check regularly on a monthly basis thereafter.

ATTENTION INSTALLER: BE SURE THAT THE CUSTOMER RECEIVES THIS INSTRUCTION SHEET, ALL IMORTANT NOTE CARDS AND THE WARRANTY FORM



559-734-7451 800-367-5480 FAX 559-734-7460

PARTS LIST

RSB KIT # 7085

PART #	QTY	DESCRIPTION
20218009	1	1-1/2" SWAY BAR
20907085	1	COMPLETION KIT
111000892	2	1-1/2" POLY BUSHING
20800787	2	U-PLATE
118020840	2	1/2" X 4" X 6-1/2" RND U-BOLT
20800761	2	SADDLE BRACKET
20800085	2	ANGLE FRAME BRACKET
20801929	2	THREADED PLTE W/PIGTAIL
101500204	2	1/2" X 8" END LINK
20800695	2	J-BOLT
125000039	1	SMALL PARTS BAG # BG-39
107521044	2	1/2" LOCK NUT
107401042	2	7/16" LOCK NUT
102400023	2	7/16" FLAT WASHER
101500125	2	1/2" X 1-1/2" CAP SCREW
105521044	8	1/2" HEX NUT
102520043	14	1/2" FLAT WASHER
120010610	2	5/8" X 2-7/8" END LINK SPACER
111000762	8	1/2" END LINK BUSHING
135000323	1	INSTRUCTION SHEET (R-323)

7085 (R-323)

05/16/07